

MAIN POWER

22 MARCH 2007

All Diodes are 1N4004

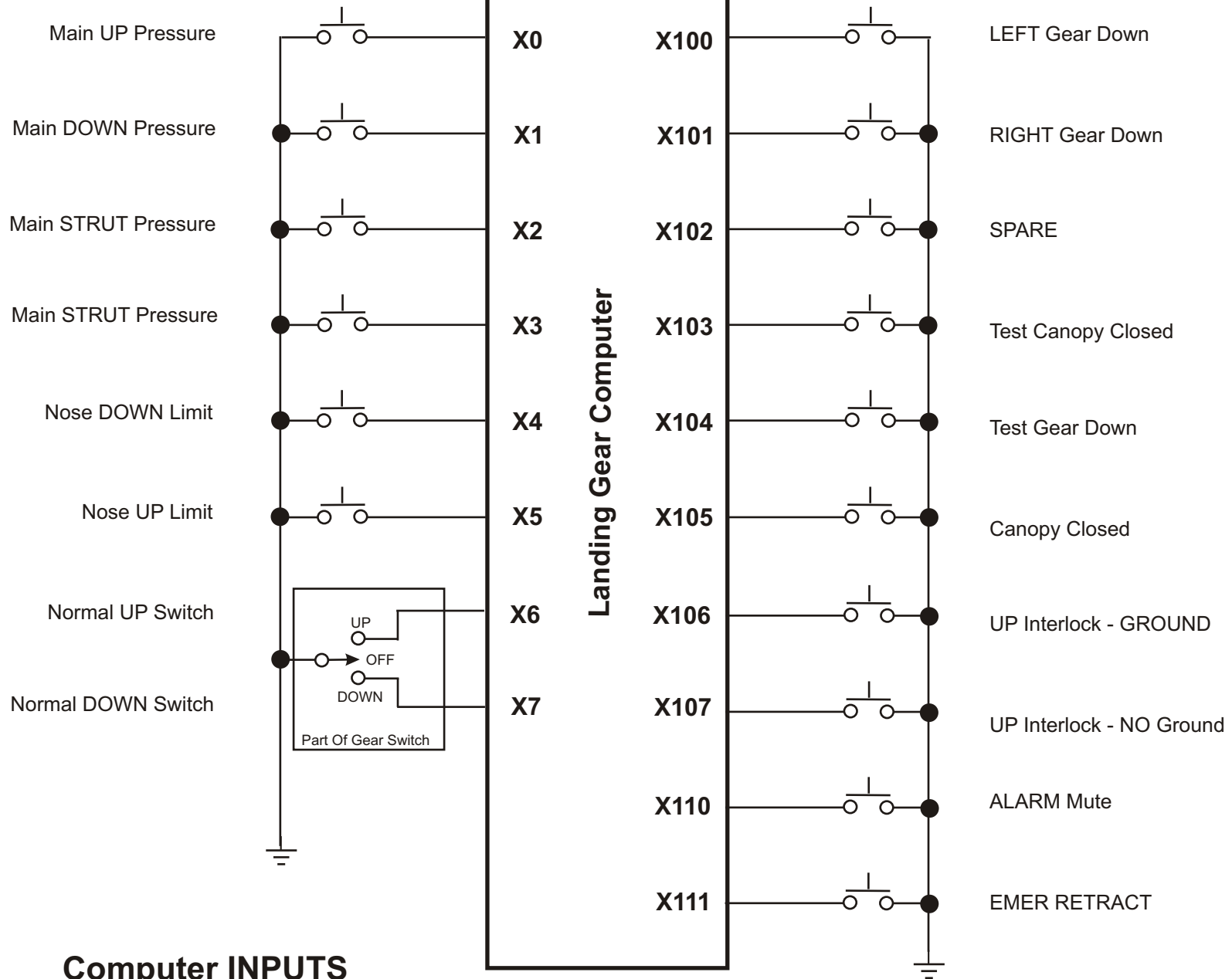

Computer INPUTS

22 MARCH 2007

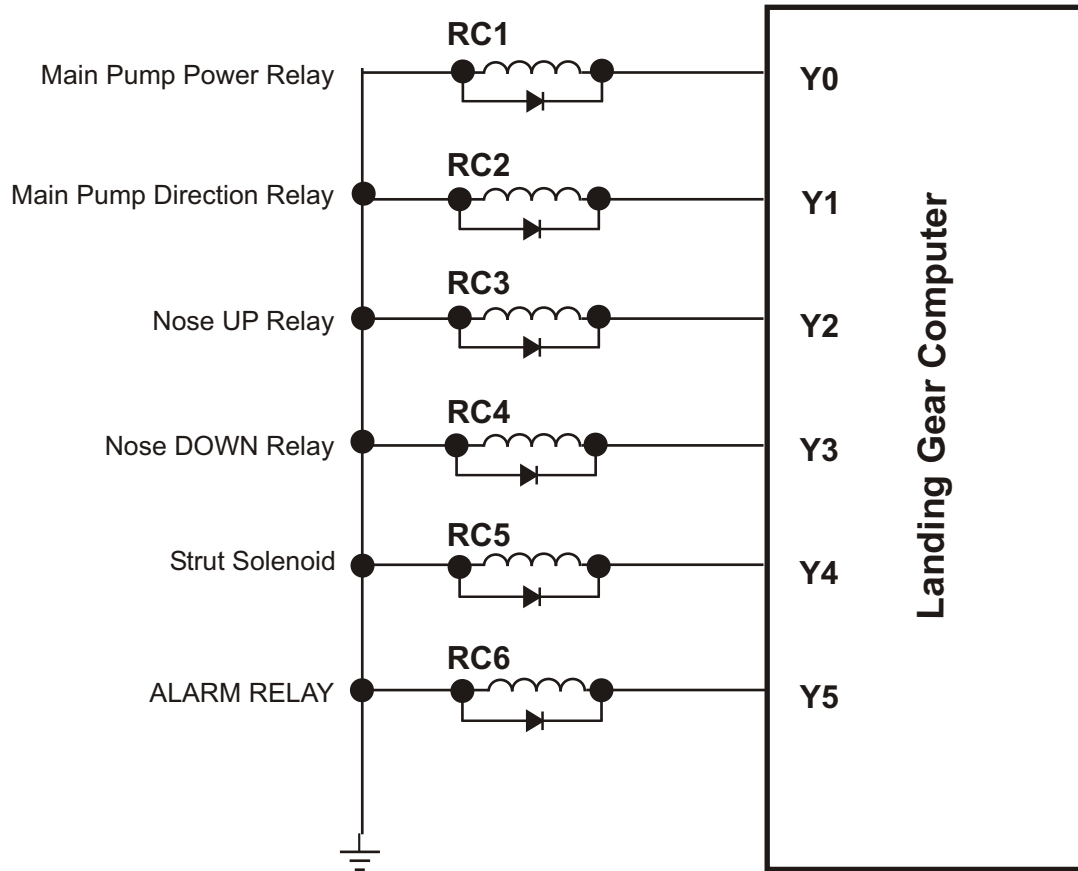

Landing Gear Computer

Computer OUTPUTS

22 MARCH 2007

All Diodes are 1N4004

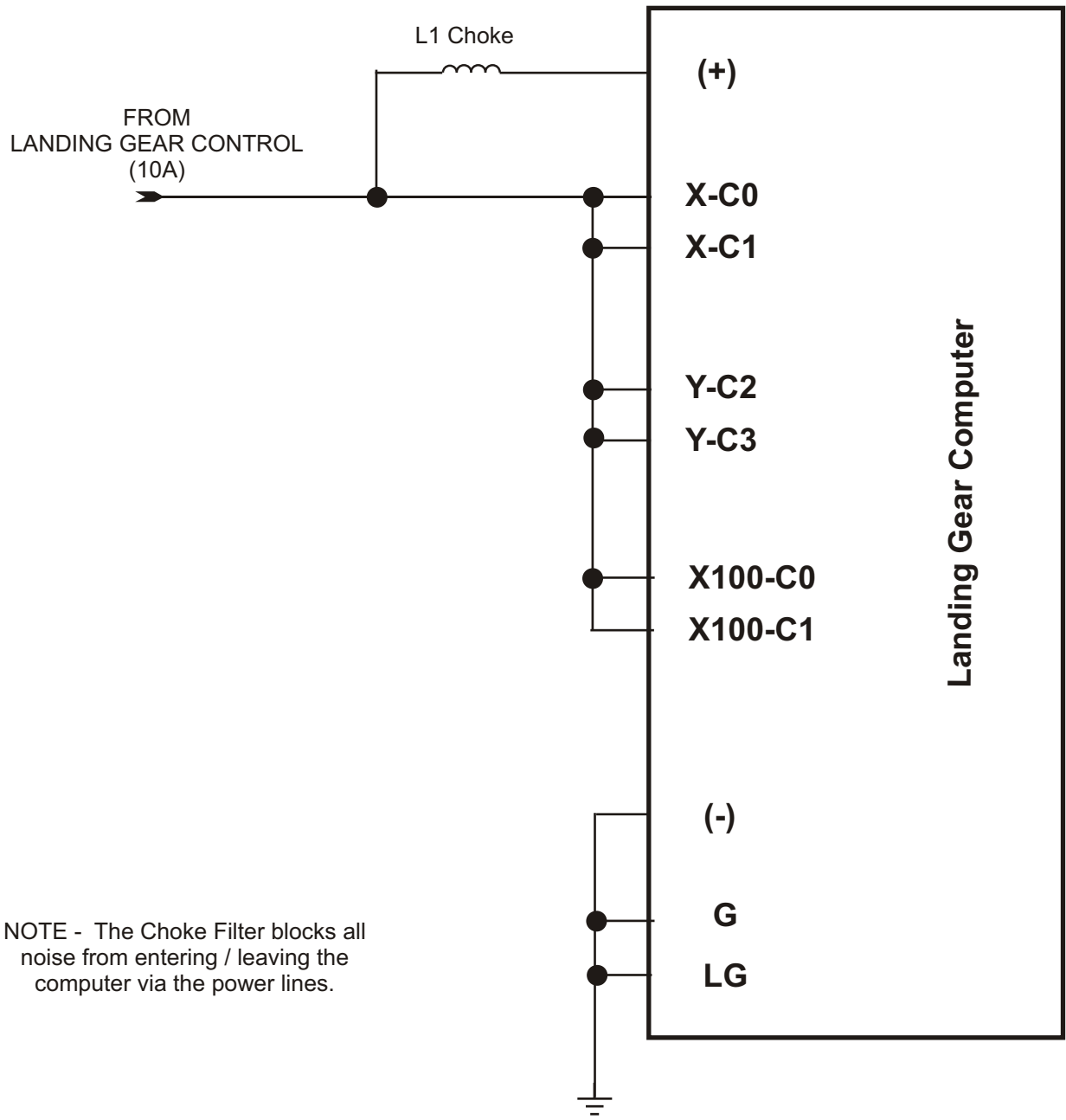

NOTE - The Choke Filter blocks all noise from entering / leaving the computer via the power lines.

Computer POWER

22 MARCH 2007

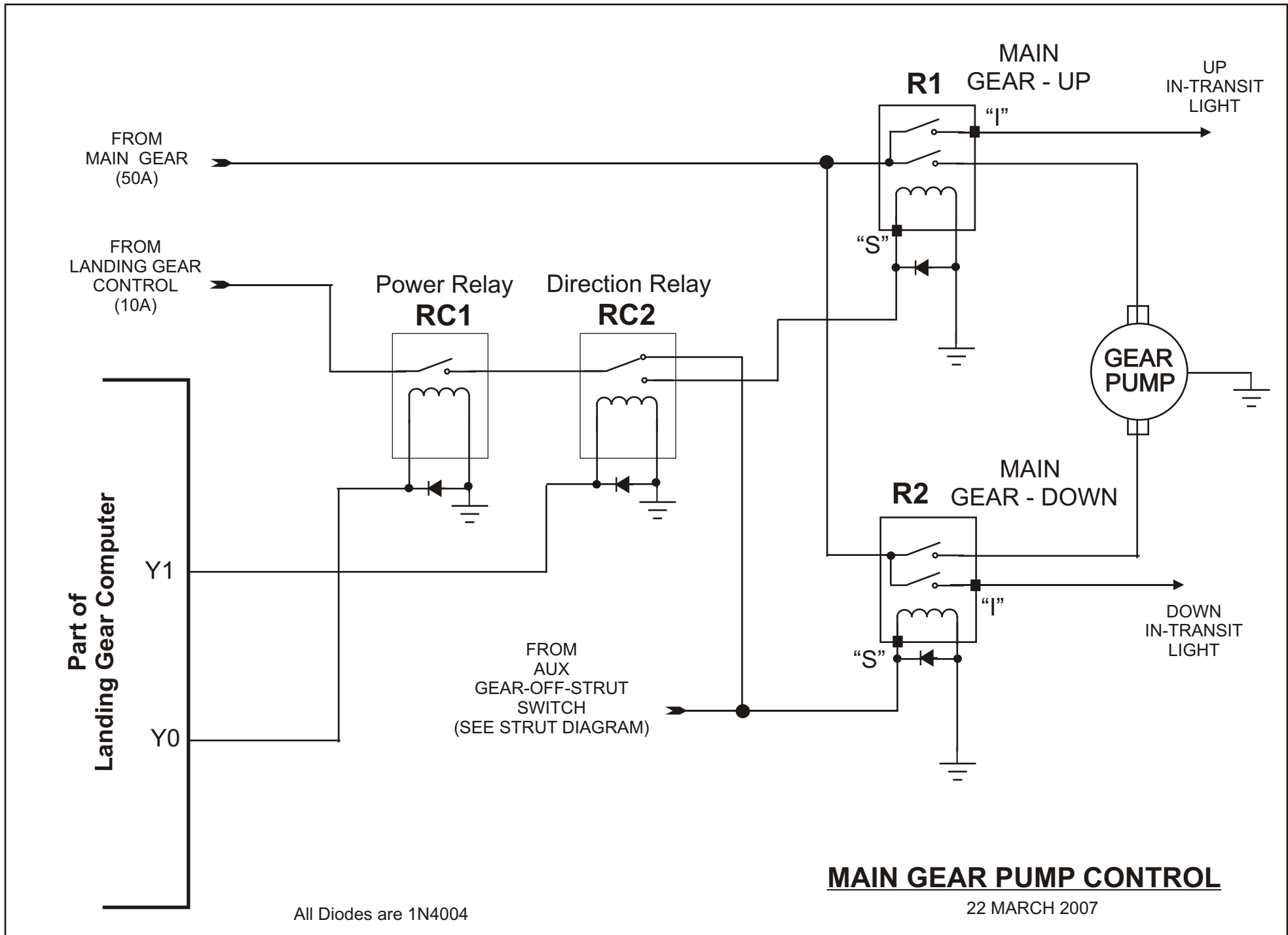

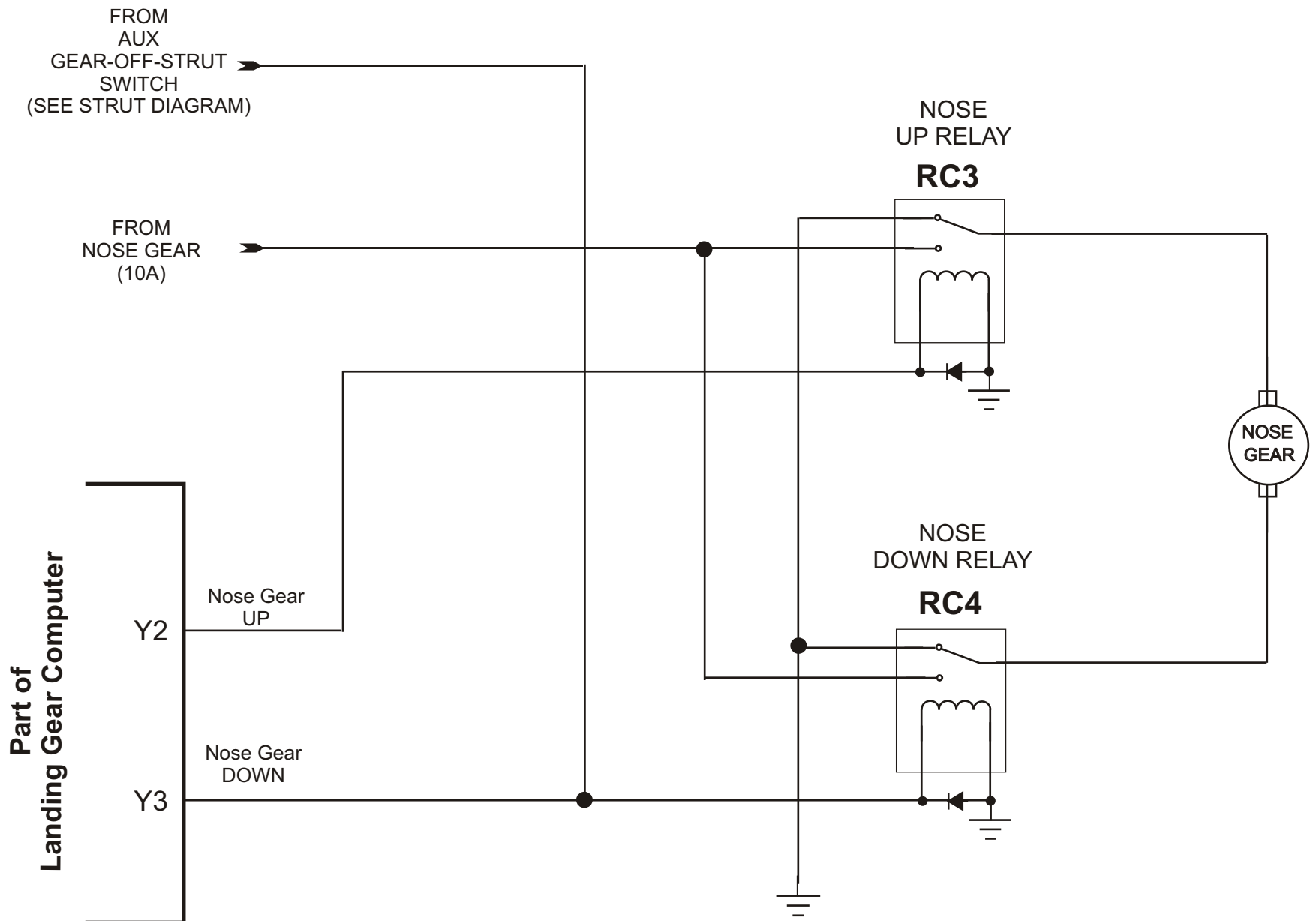

NOSE GEAR CONTROL

7 JUNE 2005

All Diodes are 1N4004

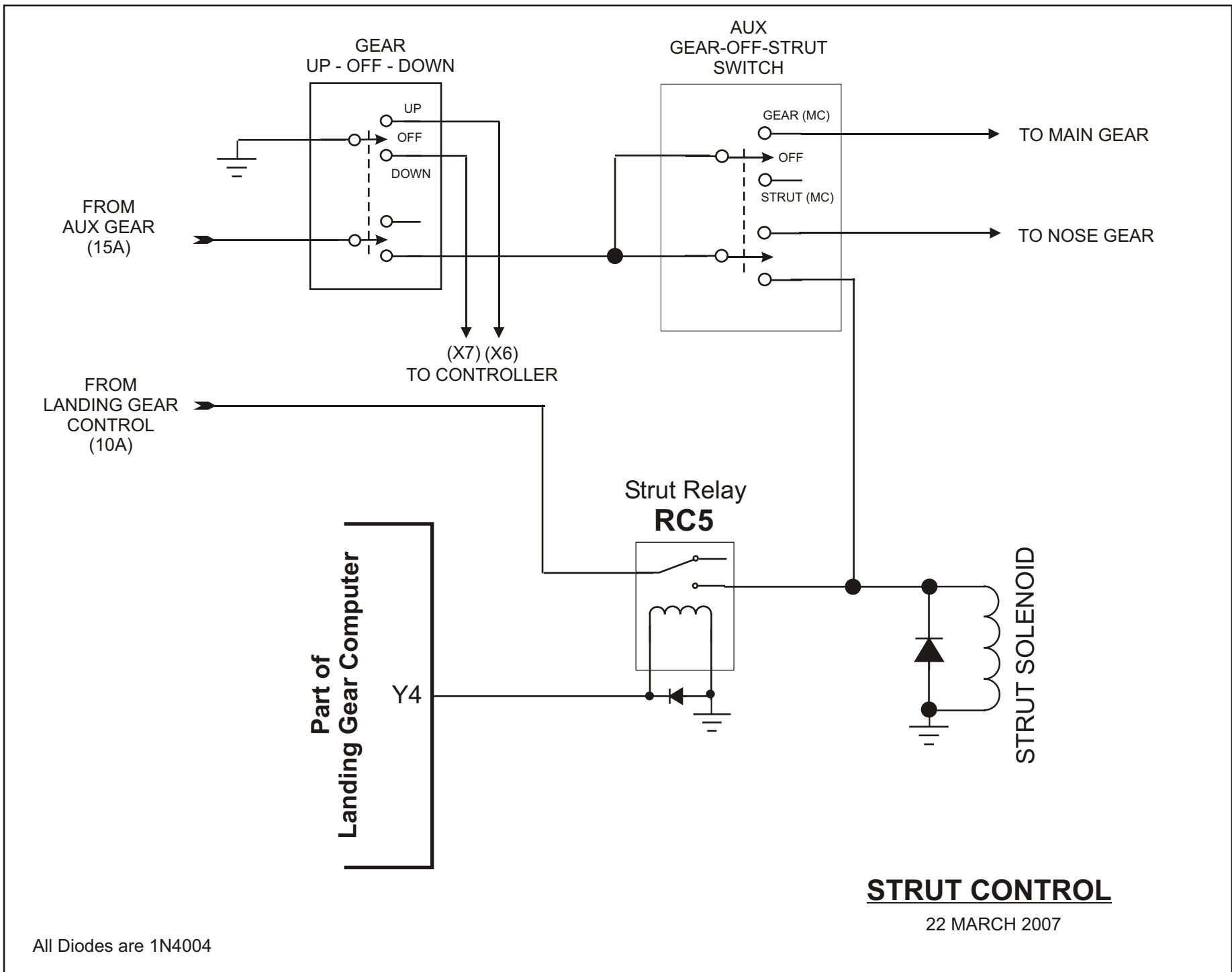

STRUT CONTROL

22 MARCH 2007

All Diodes are 1N4004

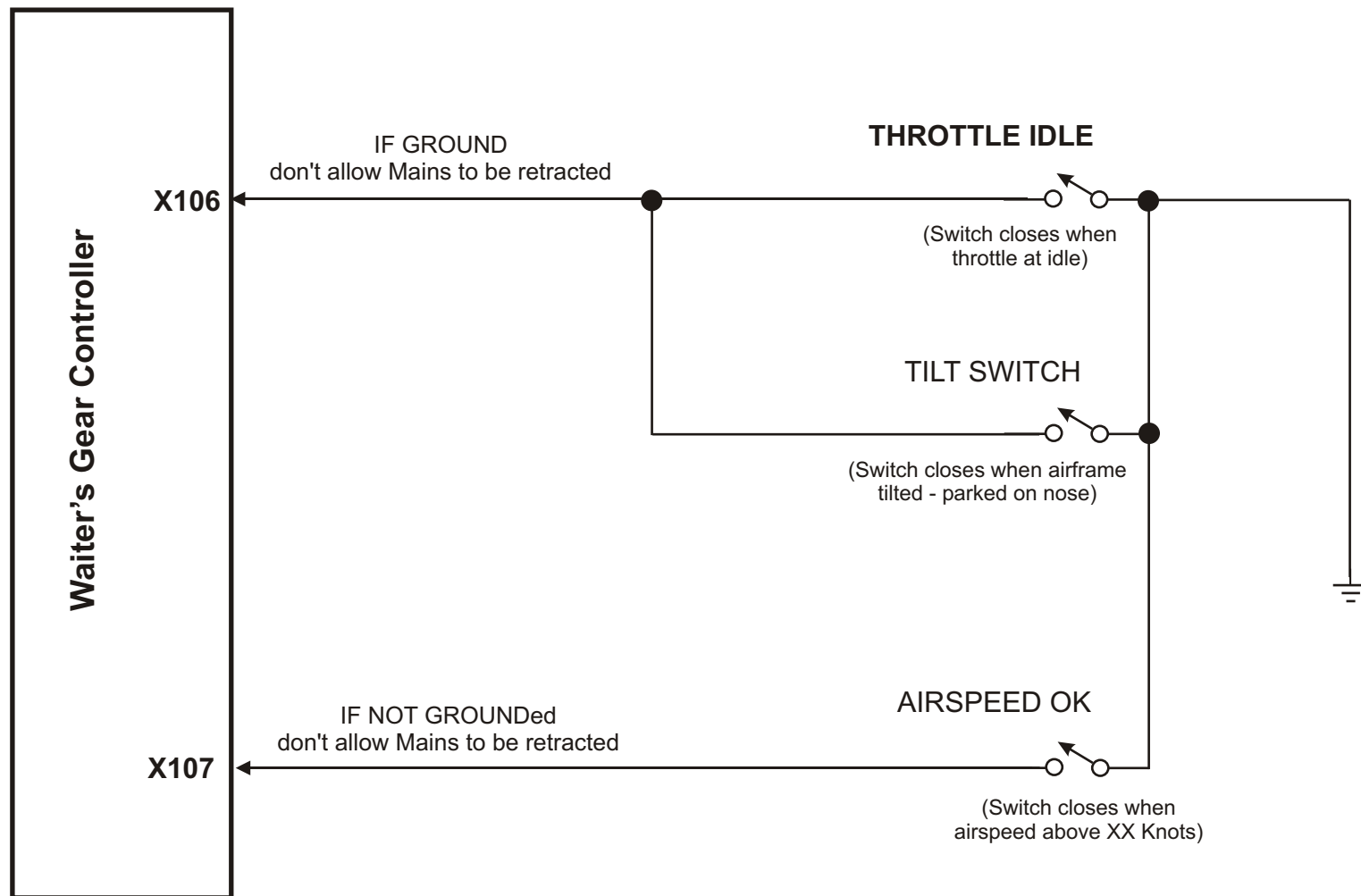

GEAR RETRACT INTERLOCK

22 MAR 2007

12 Vdc Instrument Lights

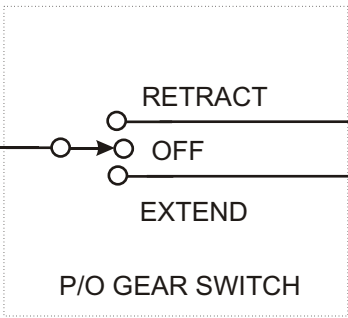

GEAR STATUS UP INDICATOR LIGHTS

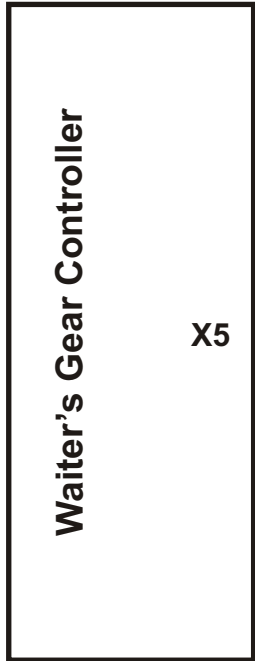
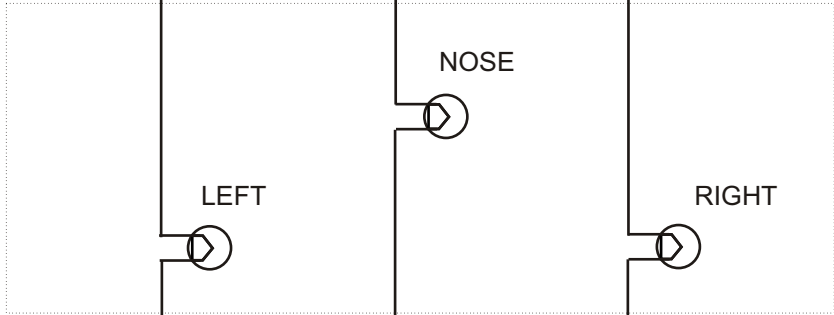

NOSE GEAR UP



All Diodes are 1N4004

GEAR "UP" INDICATORS

22 MAR 2007

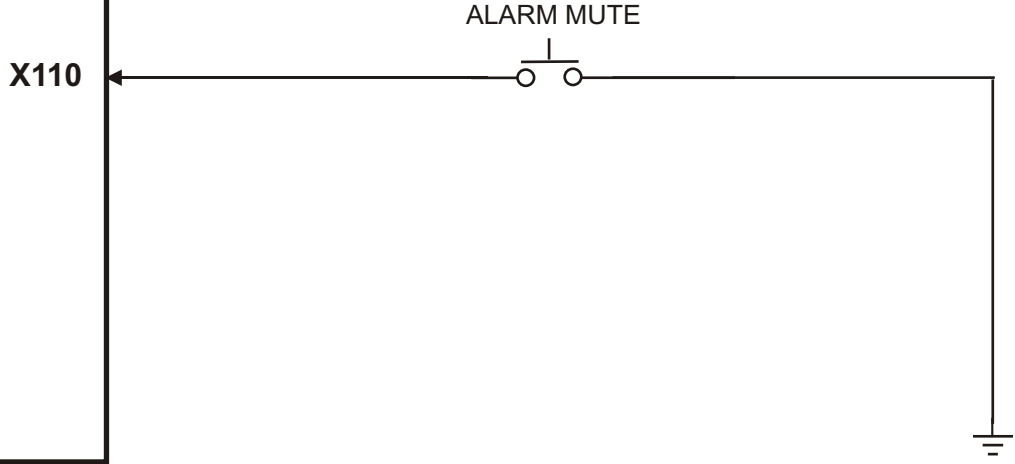
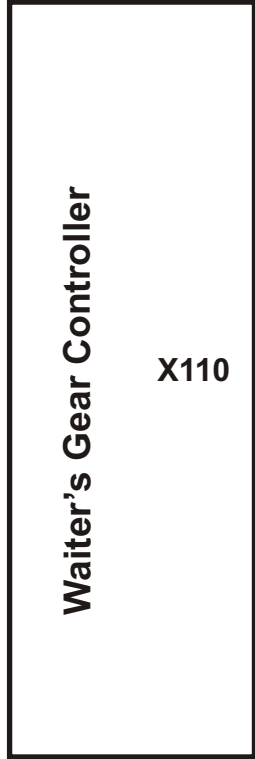

ALARM MUTE SWITCH

22 MAR 2007

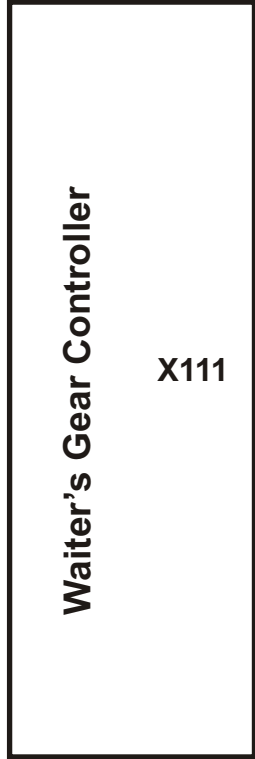

EMERGENCY RETRACT

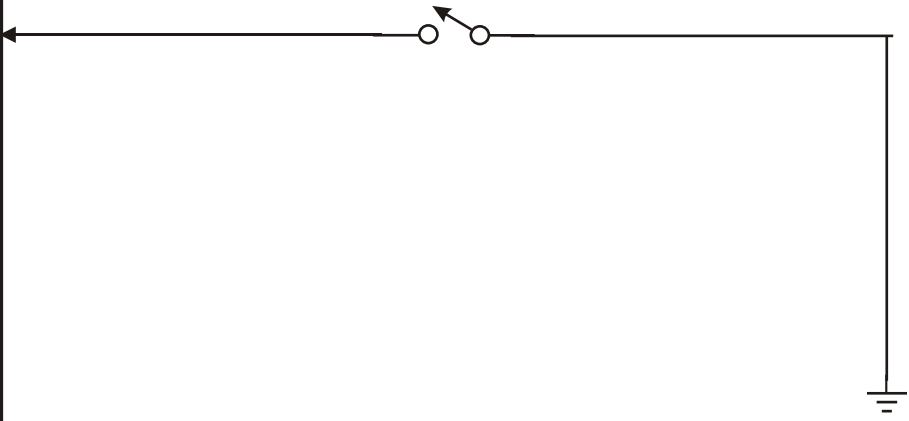

EMERGENCY RETRACT CIRCUIT

22 MAR 2007

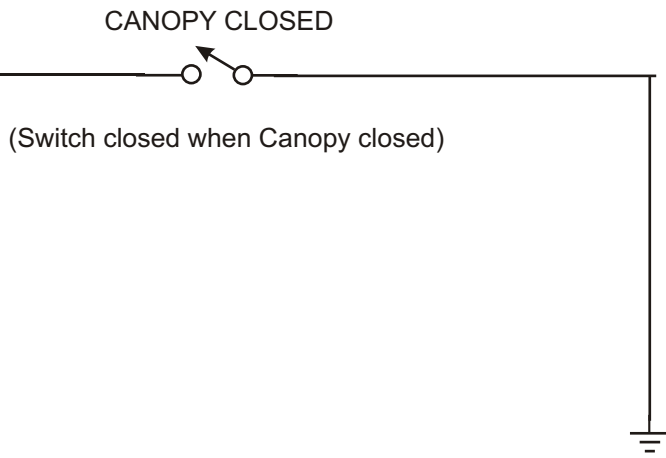
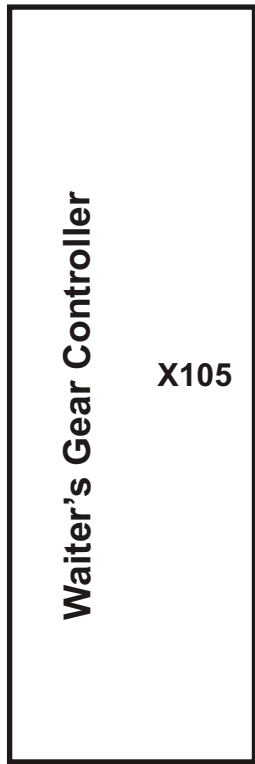

CANOPY CLOSED CIRCUIT

22 MAR 2007

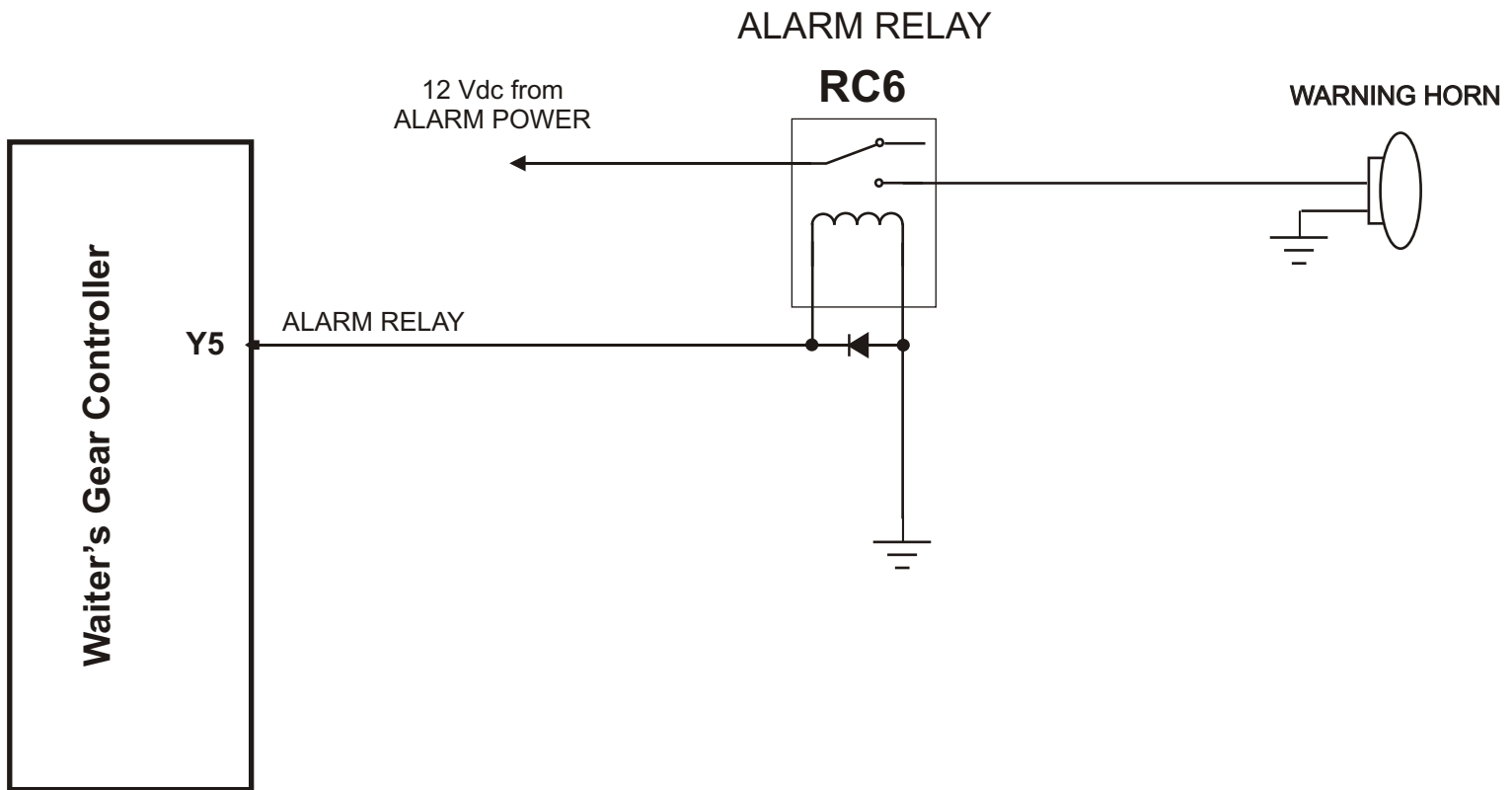

ALARM CIRCUIT

22 MAR 2007

All Diodes are 1N4004

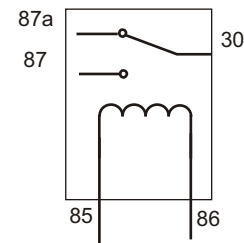
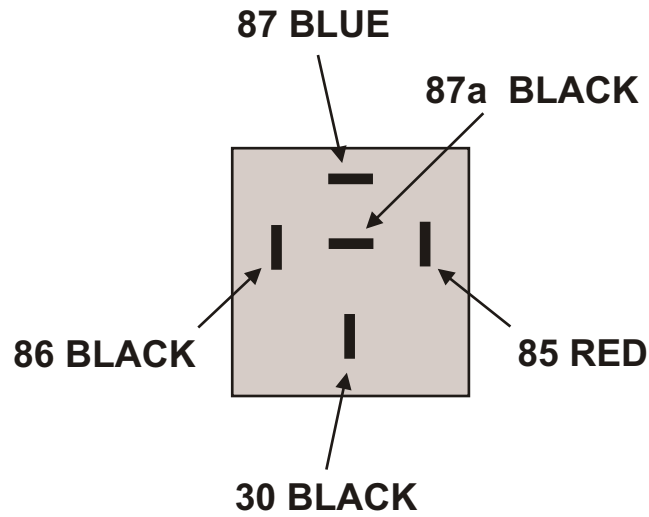

CUBE RELAY VIEWED FROM BOTTOM

10 JULY 2005

The relays and a pigtail (with suppression diode) are available from Jameco. The relays are \$2.49 each (part# 148582CH) and the pigtail is \$2.35 (Part# 170624CH)